

# SP 50 with Open Control Center *Robotic Prescription Dispensing System*

ScriptPro's SP 50 is a proven and reliable prescription dispensing system that automates the repetitive, manual dispensing tasks most subject to human error.

SP 50 interfaces with the pharmacy computer system to fill, label, and deliver up to 150 prescriptions per hour. The system contains 50 universal dispensing cells, which are easily calibrated by pharmacy staff on-site. It also has two vial dispensers and a control center, which is available in three sizes to fit your pharmacy needs. SP 50 dispenses tablets and capsules of all shapes and sizes into standard pharmacy vials. Because the system fills directly from the dispensing cells, there is no drug cross-contamination. SP 50 also prints and applies the prescription and auxiliary labels, and delivers uncapped vials for final inspection and on-screen drug image verification.



Barcodes are used throughout the process for accuracy and quality control. Pharmacy staff manages the dispensing process from prescription entry to approval of the finished product.



***ScriptPro***<sup>®</sup>

**Pharmacy Automation**

For more information call: 800.606.7628 • 913.384.1008 • [www.scriptpro.com](http://www.scriptpro.com)

# SP 50 with Open Control Center

Top View

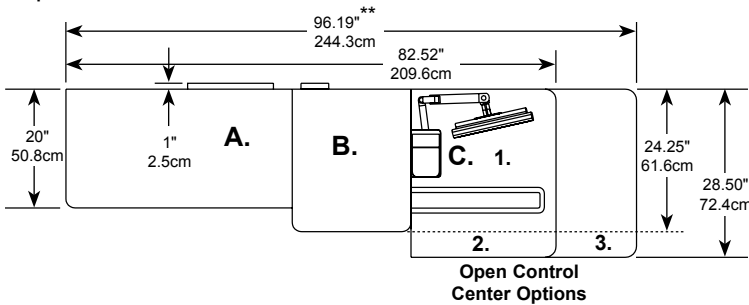

Front View

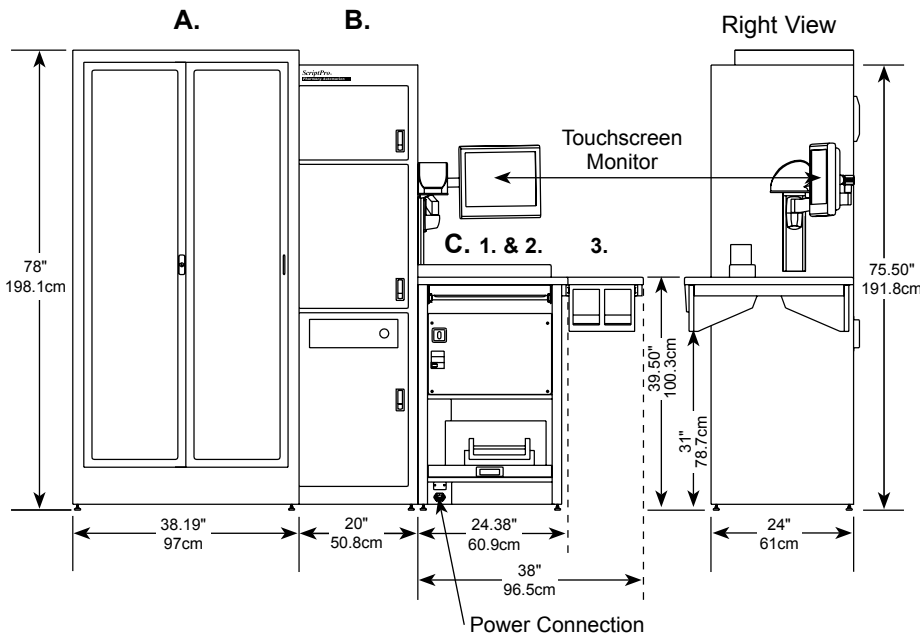

Back View

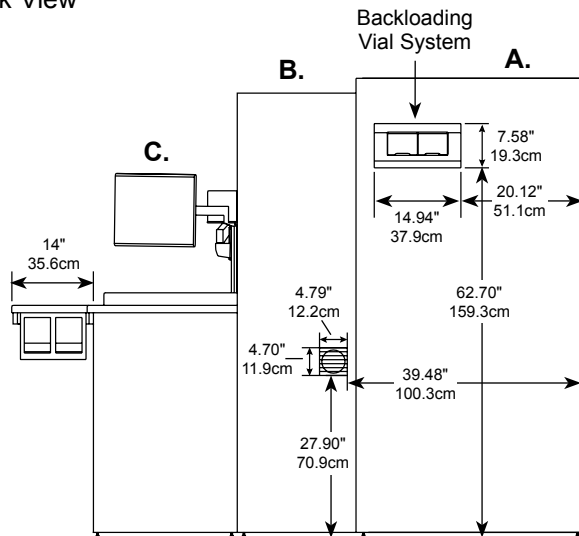

## Specifications\*

**Weight:**

- A. Robotics Cabinet: 575 lbs (260.8 kg)
- B. Electrical Cabinet: 326 lbs (147.9 kg)
- C. Open Control Center:
  - 1. 172 lbs (78 kg)
  - 2. 176 lbs (79.8 kg)
  - 3. 220 lbs (99.8 kg)

**Robot Footprint:**

- 1. 13 sq. ft. (1.2m<sup>2</sup>)
- 2. 13.9 sq. ft. (1.29m<sup>2</sup>)
- 3. 16.0 sq. ft. (1.48m<sup>2</sup>)

**Electrical Input:** 100-127 VAC, 50/60 Hz, 12 AMP (robot only; includes UPS), 16 AMP with all peripherals, 1 Phase, Uninterruptible Power Supply included. Dedicated 20 AMP power outlet located within 10 feet (3m) of power connection.

**Communications:** Serial, parallel, or ethernet pharmacy computer connection. Firewall provided for network connectivity.

**Remote Support Requirements:**

- 1. VPN over high-speed Internet connection. Also requires access to backup telephone line as specified in #2 below, such as a fax line.

OR

- 2. Modem-Dedicated analog RJ-11 telephone outlet accessible to outside line and capable of sending and receiving calls.

**Barcode Scanner - Caution:** Class IIa Laser Product. Do not stare into beam. 650nm visible laser light diode - .663 mW maximum output.

**Computer/Software:** Client/Server system on ScriptPro-installed network; Intel Core 2 Duo PCs with dual SATA drives. TCP/IP socket connections; USB connections; Software built with Visual C++; Windows XP/MSDE. Redundant data and transaction log backups. Customer access limited to SP Central user interface.

**Monitor:** 17" touchscreen with articulating arm

**Temperature:**

- Operating: 41°F to 86°F (5°C to 30°C)
- Storage: 5°F to 104°F (-15°C to 40°C)
- Relative Humidity: 20-85%
- Altitude: Up to 9,843 feet (3000m)
- Dissipated Heat: 1,844 BTU/HR max

**Cell Capacity:**

- Single Cell: 676 cc/183 dram
- Extended Cell: 1900 cc/514 dram

**Peripheral Products Supported:**

See product sheet on peripheral products

**ANSI Barcode Print Quality Grade:** B

**Sound Level:** 77 db at front edge of Control Center

**Training:** Up to four Full Time Equivalent (FTE) training days included with original lease/purchase. Approx. two FTE days for Training and Setup and approx. two FTE days for Go-Live and Support.

One "FTE" day is defined as one trainer on-site for one day for up to 10 hours. If more than one trainer is on-site, it is counted as multiple FTE days.

\* Specifications subject to change without notice.

\*\* Requires one additional inch clearance for installation.



**ScriptPro®**

**Pharmacy Automation**

For more information call: 800.606.7628 • 913.384.1008 • www.scriptpro.com

November 2011